

Steel-Armored HDMI 2.0 AOC Hybrid Cable

extremely robust and durable

flexible cable incl. steel armoring

high pressure and crush resistance

high performance up to 100 meters



Specification	Features / Technical Data	Application
connector 1: HDMI-A Source	metal housings	public environments
connector 2: HDMI-A Display	data transmission: up to 18 Gbps	industry / engineering
cable: 4x fibers / 8x copper wires	image resolution: up to 4K/60 Hz	train stations / airports
outer diameter: 5.8 mm	RGB: 4:4:4	events
jacket material: TPU	temperature range: 0°C up to +50°C (operation)	home cinema systems
armoring: 200CU steel		medical technology
protection sleeve with screw-cap: both sides		

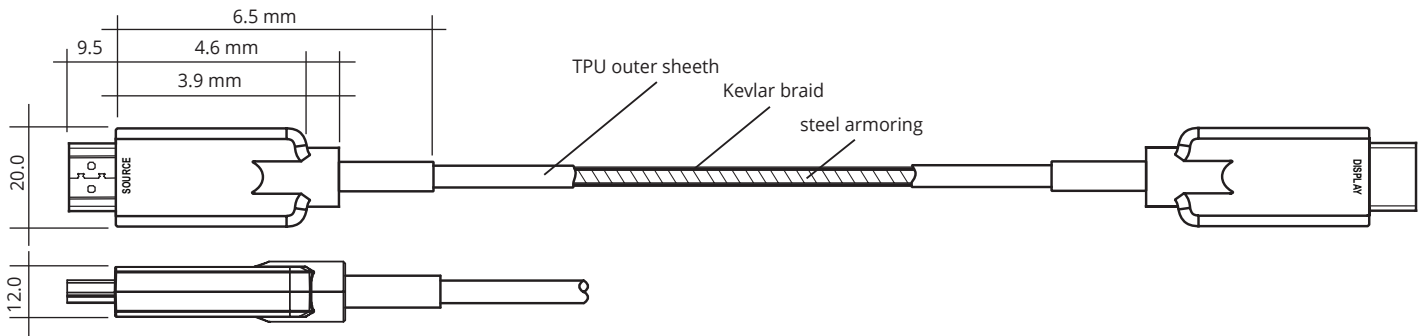

Tests	Standards
bending radius: 10x Ø (dynamic) 20x Ø (static)	HDMI 2.0
pressure resistance: 1000N/100 mm (long term) 2000N/100 mm (10 minutes)	IP64 (protection sleeves)
tensile resistance: 400N/40 kg (long term) 800N/40 kg (10 minutes)	

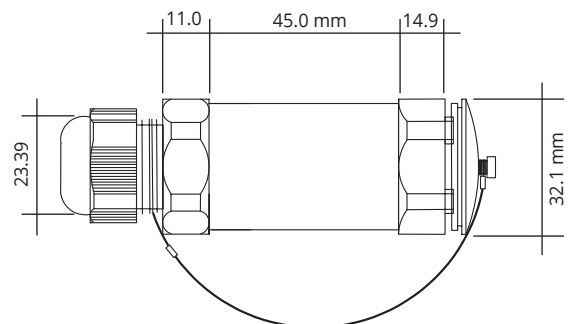

Colour: ■ black (cable) ■ anthracite (plugs)

Art. No.	EAN No.	Length ± Tolerance (mm)
HDMI-AAOC-15,0M-2	4260310265117	15.000±250
HDMI-AAOC-30,0M-2	4260310265124	30.000±400
HDMI-AAOC-50,0M-2	4260310265131	50.000±1000
HDMI-AAOC-100,0M-2	4260310265094	100.000±1000

Accessory
(application optional)



HDMI / USB Adapter Cable
for power supply DC 5V

Length: 20 cm
Art. No. HMHF+USB-0,20M

