

8x TtLan® Cat.6_A Keystone Module 500 MHz / 10 GBit

GHMT component-certified

compact size

tool-free installation

fully shielded

design compatible



environmental-friendly packaging

2 combs for different cable cross sections

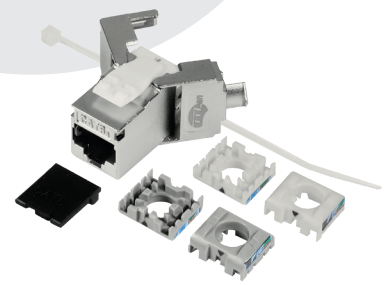

Specification	Technical Data / Tests	Standards / Certificates
connector: RJ45 socket	data transmission: 500 MHz / 10 Gbps Ethernet with	Category: 6 _A
suitable for cables with AWG 22 - 24	high system reserve	GHMT® component standard: ISO 11801
360° shield connector	contacts with 50µ gold-plating	
compact design	temperature range: -10°C up to +60°C	
material: zinc die-cast	mating cycles: >750	
mounting: without tool	cable support and shield contact by cable tie	

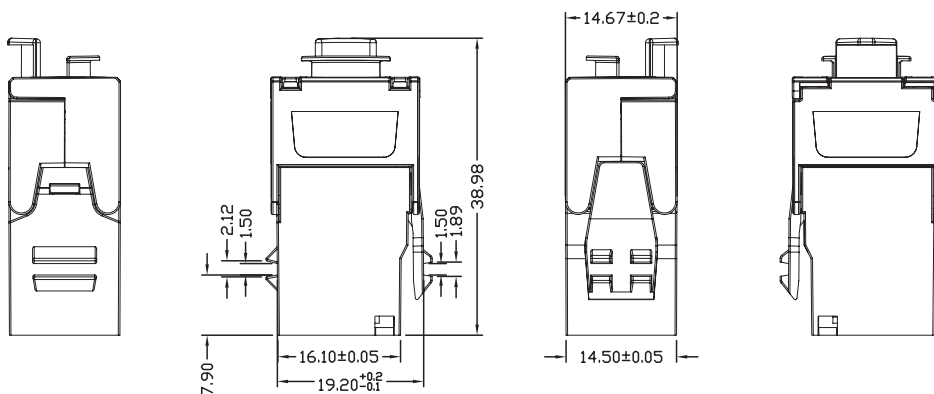

Art. No.	EAN No.
1808-8	4260310265452



TTL Network GmbH
 Neulehenstr. 8C
 33790 Halle (Westfalen)
 Germany
 Tel.: +49 5201 85660-00

Business hours

Mo - Thu: 8:00 am - 5:00 pm
 Fr: 8:00 am - 2:00 pm

Mail: info@ttl-network.de

www.ttl-network.de

